

ISSUE 30

MAGAZINE FOR ARCHITECTURAL
ENTERTAINMENT SPRING/SUMMER 2021



FRANK O. GEHRY
PHOTOGRAPHED BY BUCK ELLISON

LEGACY

ISSUE 30



MAGAZINE FOR ARCHITECTURAL
ENTERTAINMENT SPRING/SUMMER 2021

NEW NEW YORK ARCHITECTS
PHOTOGRAPHED BY TANYA AND ZHENYA POSTERNAK



LEGACY

Swiss Precision



An anonymous Swiss inventor's DIY love machine, which is adjustable for single or dual use. A variety of dildos, Fleshlights®, or other pleasure aids can be installed via universal adapters.

In winter, social life in Switzerland decreases exponentially with the temperature, and even more so during a pandemic. Like many, I started dodging the boredom by hunting down used furniture on online marketplaces. Unexpectedly, a search for classic Horgenglarus chairs diverted me to a listing for an enigmatic “love machine” named LM42P. A triangular device, available in seven colors, it supports one or more sex toys at its extremities.

LM42P is straightforward, yet hard to pin down or classify. Is this some sort of Duchampian bachelor machine? (A myth to which curator Harald Szeemann dedicated an entire exhibition in 1975). Or are we looking at a kinetic Surrealist sculpture authored by the secret son of artists Jean Tinguely and Meret Oppenheim? The mystery remained intact after I reached out to its creator, a 46-year-old electro-mechanical engineer who agreed to be interviewed on condition of anonymity.

“I wanted to make a device that would allow me to have an orgasm without the use of my hand,” the Lausanne-based inventor explains. “My wife doesn’t want sex anymore. So I just feel a bit less guilty if I don’t stroke my penis myself.” With seasoned Swiss precision (case in point: his exacting technical drawings), the pragmatic husband developed LM42P’s first prototype in 2015. His accounts of early experiments suggest a wild ride: “I used the mechanism of an old inkjet printer. Instead of the printhead, I attached a rod to the end of which a plastic

bottle was taped. It worked, but during orgasm, the inflation blocked the motor because it lacked power.”

The subsequent search for a more powerful and compact motor led, after four years of development, to the present version of the machine. LM42P is an acronym for “Love Machine For Two People,” and it can provide both a phallus and an orifice function, both Fleshlights® and dildos plugging into the arms via a sort of universal adapter.

More interestingly though, the machine needs a host to be fixed to — a base strong enough to resist the kinetic forces it engages. In this truly opportunistic way, the LM42P perverts and parasites “innocent” furniture. For support, the device’s creator suggests that a coffee table is ideal, because “it is heavy enough to stay in place. The frame of a bed is also excellent, a door frame is possible, and a table leg works as long as it is not round.” With all these options, one can think of more than a few modern design classics that could be candidates for misappropriation.

After working on this project for six years, the engineer dreams of finding an investor for his device, whose commercial potential he has persuasively illustrated through product photos and a minimalist logo. He also plans to design an app so the LM42P can be controlled via a smartphone. For the time being, and without a safety label, it is only available as a self-assembly kit: you can create your own through 3D-printable parts and an open-source manual. Be warned, though: “LM42P cannot be held responsible for any machine malfunction resulting in injury. This machine is to be used at your own risk.”

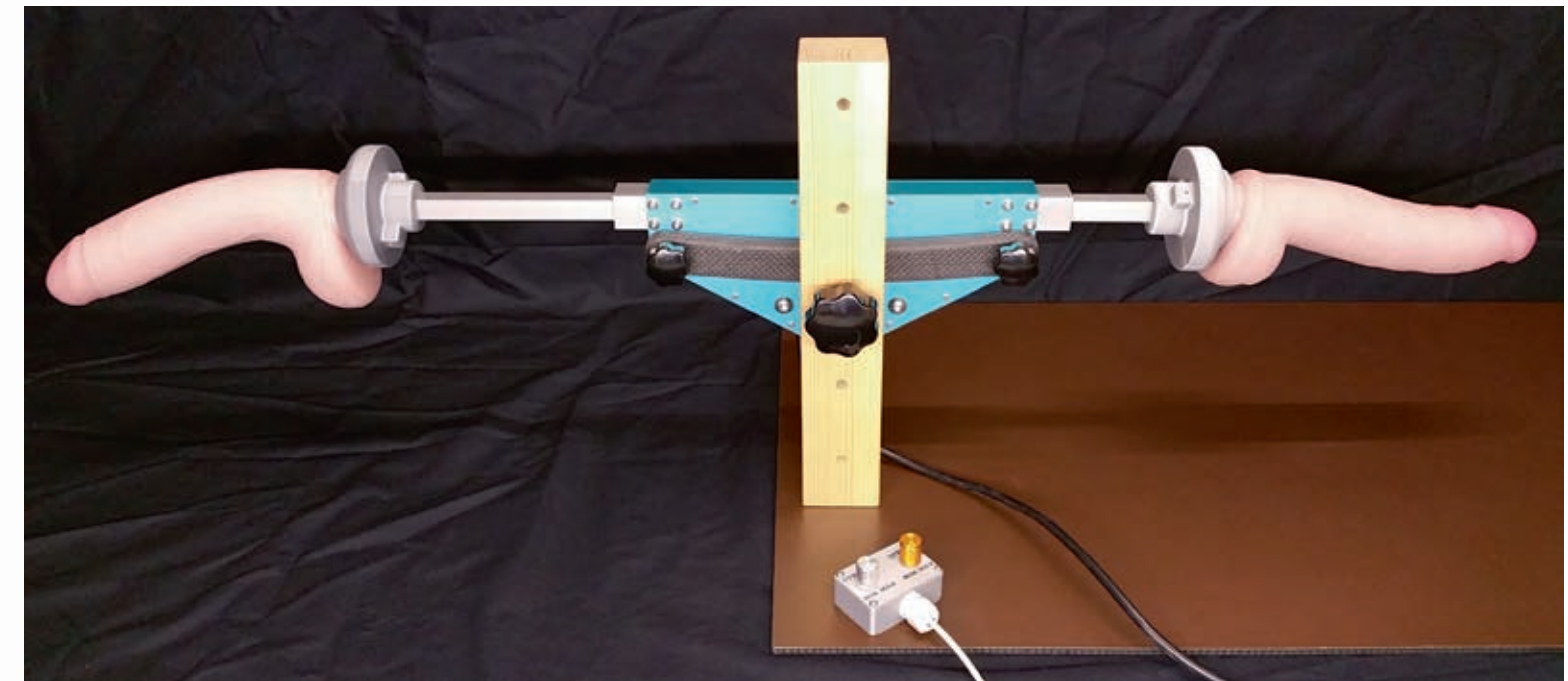
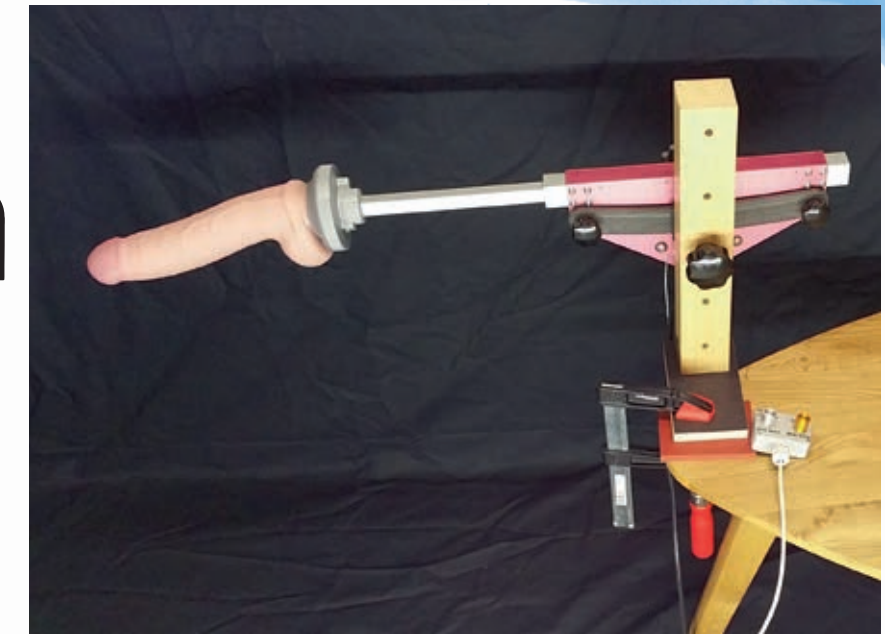

3.2 Dildo Big balls Pyrex Glass Anal

Opérateur	Figures	Description
1		A dildo with a diameter of 100 mm and a length of 150 mm. The glass ball has a diameter of 100 mm.
2		A dildo with a diameter of 100 mm and a length of 150 mm. The glass ball has a diameter of 100 mm.
3		A dildo with a diameter of 100 mm and a length of 150 mm. The glass ball has a diameter of 100 mm.

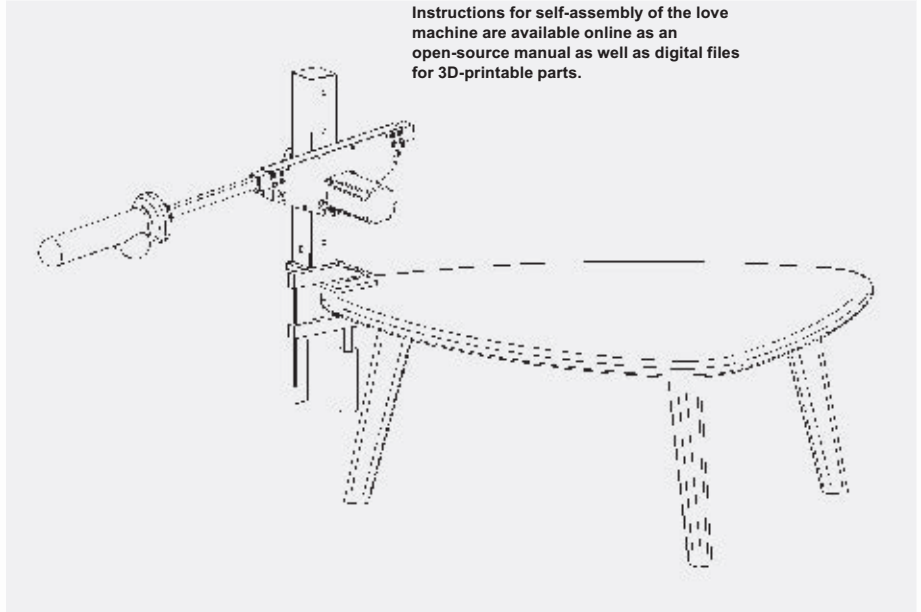

Instructions for self-assembly of the love machine are available online as an open-source manual as well as digital files for 3D-printable parts.

TEXT BY
ANDREAS KOFLER